



MILBANK[®]
ENERGY AT WORK

K4802



Catalog Number	K4802
Marketing Product Description	Anti-inversion Kit Used In 320a Self-contained Sockets
UPC	784572247710
Length (IN)	7
Width (IN)	1.5
Height (IN)	5
Weight (LB)	0.05
Brand Name	Milbank
Type	Mounting Accessory
Special Features	Anti Inversion Kit
Application	Metering Accessory
Material	Steel
Size	7L x 1.5W x 5H
Color	Unpainted
Insulation	None
Knockouts	False
Misc	Anti Inversion Clip; Information Label; Installation Sheet

Please consult serving utility for their requirements prior to ordering or installing, as specifications and approvals vary by utility and may require local electrical inspector approval. All installations must be installed by a licensed electrician and must comply with all national and local codes, laws and regulations. Milbank reserves the right to make changes in specifications and features shown without notice or obligation.

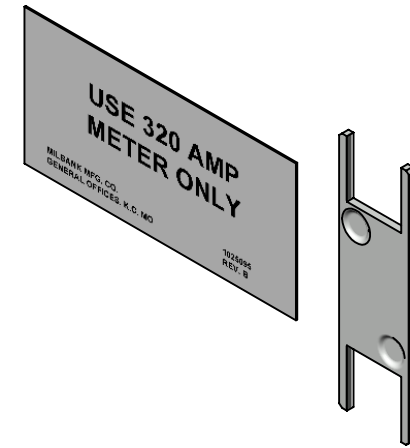
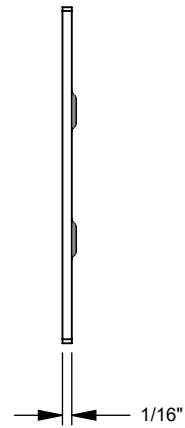
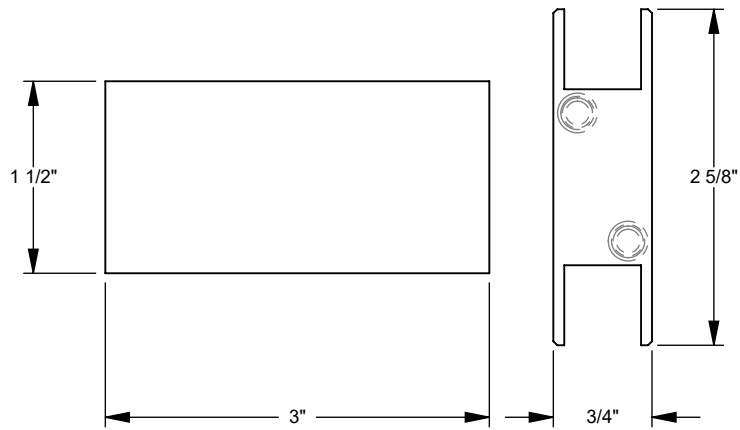

Version:

1

All dimensions are +/- 1/16".
Drawing views are not to scale.

Please consult serving utility for their requirements prior to ordering or installing, as specifications and approvals vary by utility, and may require local electrical inspector approval. All installations must be installed by a licensed electrician and must comply with all national and local codes, laws and regulations. Milbank reserves the right to make changes in specifications and features shown without notice or obligation.